

# MECBO

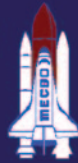

# SHUTTLE



## TRUCK MOUNTED PUMP

Truck	2 axles
Weight	6.5 - 7.5 TON
Pumping group	P2 / P4

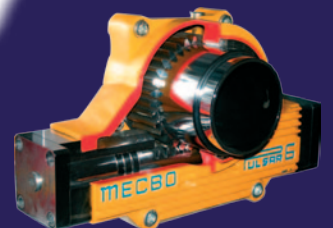

**PULSAR SYSTEM**

**SHUTTLE P2.15**

**SHUTTLE P4.25**

**6.5 TON**

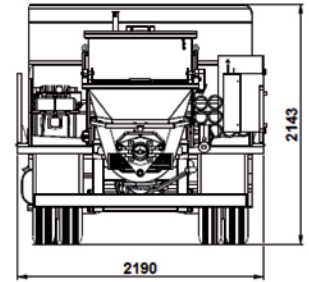
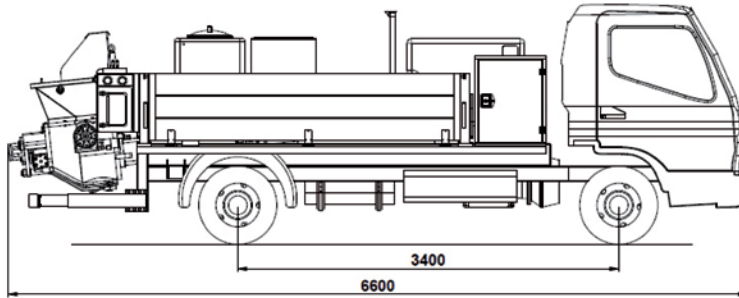

**SHUTTLE P4.40**

**SHUTTLE P4.65**

**6.5 / 7.5 TON**

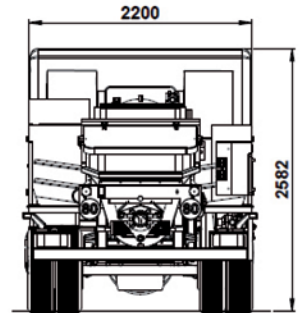
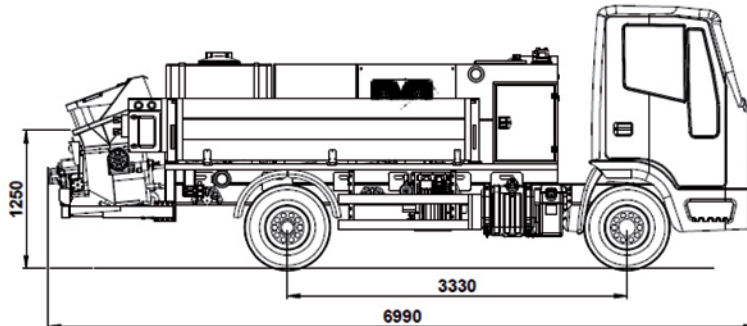

**GRUPPO POMPANTE  
PUMPING GROUP  
GROUPE DE POMPAGE  
PUMPENGRUPPE**

Pompa tipo Pump type Pompe type Pumpentyp	<b>P2.15</b>	<b>P4.25</b>	<b>P4.40</b>	<b>P4.65</b>
Diametro dei cilindri Cylinders diameter Diamètre cylindres Zylindersdurchmesser	<b>120 mm</b>	<b>150 mm</b>	<b>180 mm</b>	<b>180 mm</b>
Corsa Stroke Course Schlaganfall	<b>800 mm</b>	<b>1000 mm</b>	<b>1000 mm</b>	<b>1400 mm</b>
Diametro uscita Outlet diameter Diamètre sortie Austrittsdurchmesser	<b>120 (5")</b>	<b>125 mm (5" 1/2)</b>	<b>125 mm (5" 1/2)</b>	<b>125 mm (5" 1/2)</b>
Volume tramoggia Hopper capacity Capacité trémie Kapazität des Trichters	<b>300 l</b>	<b>380 l</b>	<b>380 l</b>	<b>380 l</b>
Pressione in uscita Outlet pressure Pression sortie Betondruck	<b>50 bar</b>	<b>70 bar</b>	<b>70 bar</b>	<b>70 bar</b>
Portata calcestruzzo Concrete output Débit béton Beton Formermenge	<b>15 m<sup>3</sup>/h</b>	<b>25 m<sup>3</sup>/h</b>	<b>40 m<sup>3</sup>/h</b>	<b>65 m<sup>3</sup>/h</b>

*Macchine prodotte con doppio circuito idraulico – Machines produced with double hydraulic circuit - Machines produites avec double circuit hydraulique - Maschinen hergestellt mit doppelt Hydraulikschaltung*

**OPTIONAL – EN OPTION –  
FAKULTATIV**

VIBRATORE – VIBRATOR  
VIBRATEUR – VIBRATOR

POMPA ACQUA – WATER PUMP  
POMPE A EAU – WASSERPUMPE

SERBATOIO ACQUA – WATER TANK  
RESERVOIRE D'EAU – WASSERTANK

COMPRESSORE – COMPRESSOR  
COMPRESSEUR – KOMPRESSOR

TELECOMANDO CON CAVO  
REMOTE CONTROL BY CABLE  
TELECOMMANDE AVEC CABLE  
FERNSTEUERUNG MIT KABEL

RADIO COMANDO – RADIO REMOTE CONTROL  
RADIOCOMMANDE – RADIO FERNSTEUERUNG

TUBAZIONE E ACCESSORI  
PIPELINES AND ACCESSORIES  
TUYAUTERIES ET ACCESSOIRES  
ROHRLEITUNG UND ZUBEHÖRE

KIT x POMPAGGIO SPRITZ – SHOTCRETE KIT  
KIT POUR PROJECTION – SPRITZBETON KIT

LUBRIFICAZIONE AUTOMATICA LINCOLN  
LINCOLN AUTOMATIC LUBRICATION  
LUBRIFICATION AUTOMATIQUE LINCOLN  
AUTOMATISCHE SCHMIERUNG LINCOLN

MOTORE AUSILIARIO – AUXILIARY ENGINE  
MOTEUR AUXILIAIRE – HILFSMOTOR

I presenti dati tecnici hanno valore indicativo. Con l'evolversi della tecnologia, i dati esposti potranno subire modifiche senza preavviso. Le richieste tecniche specifiche debbono essere sempre accettate dalla nostra Direzione con conferma scritta. The present technical data have indicative value. Owing to the technology development, all above mentioned details may be changed without any notice. All specific technical request must be always accepted from our Management by written confirmation.